

Chameleon Portable



- Specifications -



Portable double sided whiteboard

The surroundings are important for the creative process. If you always stay in the same place, you literally and figuratively find yourself boxed in. So if you want to think outside the box, take your team outside. And don't forget to take your Chameleon Portable with you. This whiteboard can be taken anywhere. And back at the office, put it back where it was. The design is influenced by Scandinavian design, using a real leather strap and lovely minimalist buckles.

Specifications



General - Size M

Art. number:	15300.001
Outside dimension excl. hanger (H x W x D):	828 x 828 x 42 mm
Outside dimension incl. hanger (H x W x D):	958 (± 30 mm) x 828 x 42 mm
Writing surface:	Dubbel sided white enamel (Indoor Air Quality Certified to SCS-EC10.3-2014 v4.0)
Gross weight:	10,4 kg
Nett weight:	5,4 kg
Charastaristics:	Magnetic and dry erasable, portable/moveable
Guarantee:	2 years
Guarantee surface:	25 year on writability and dry erasability

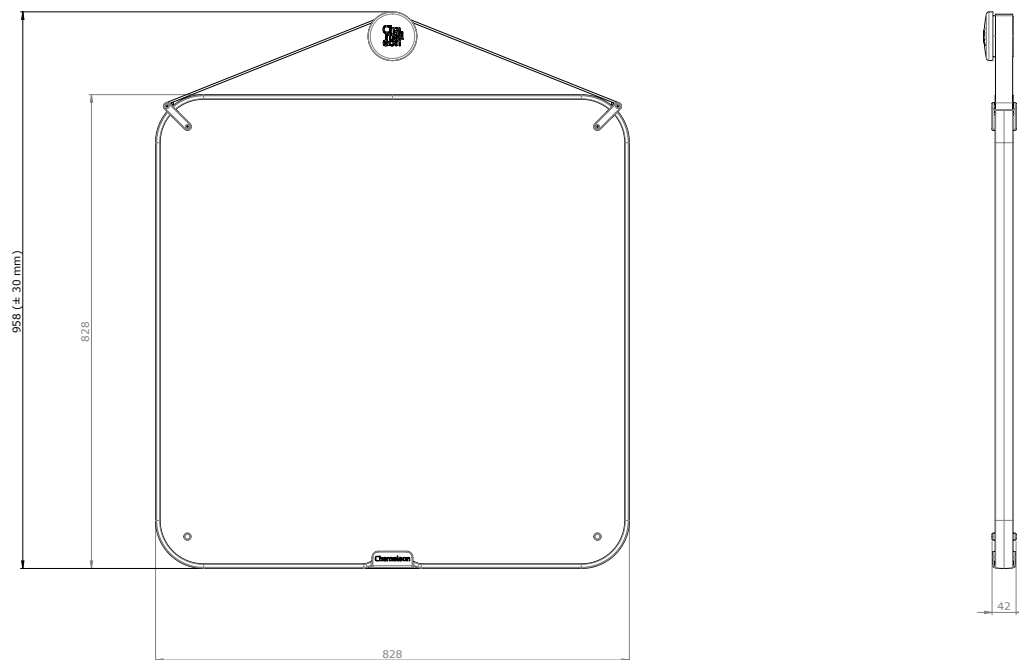

Packaging

Type:	Crate
Packing unit:	1 unit
Materials:	Pinewood + currogated cardboard + foamstrip + handwrap foil
Size (W x D x H):	(+/-) 1006 x 958 x 800 mm
Weight packaging:	(+/-) 5 kg

Specifications



General - Size L

Art. number:	15300.002
Outside dimension excl. hanger (H x W x D):	Portrait: 1128 x 832 x 42 mm Landscape: 828 x 1132 x 42 mm
Outside dimension incl. hanger (H x W x D):	Portrait: 1270 (± 30 mm) x 832 x 42 mm Landscape: 1004 (± 30 mm) x 1132 x 42 mm
Writing surface:	Dubbel sided white enamel (Indoor Air Quality Certified to SCS-EC10.3-2014 v4.0)
Gross weight:	13.55 kg
Nett weight:	7.55 kg
Charastaristics:	Magnetic and dry erasable, portable/moveable
Guarantee:	2 years
Guarantee:	25 year on writability and dry erasability

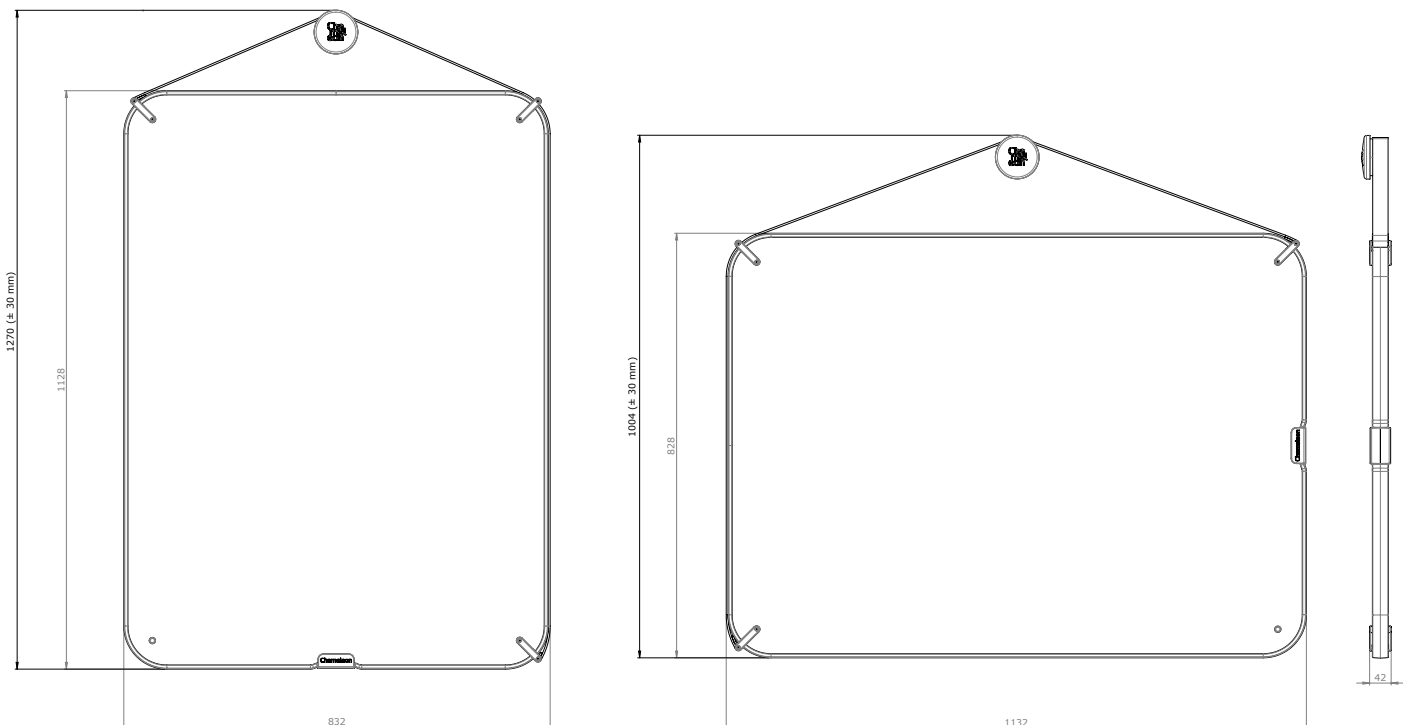

Packaging

Type:	Crate
Packing unit:	1 unit
Materials:	Pinewood + currogated cardboard + foamstrip + handwrap foil
Size (W x D x H):	(+/-) 1006 x 1262 x 80 mm
Weight packaging:	(+/-) 6 kg

Specifications



General - Size XL

Art. number:	15300.003
Outside dimension excl. hanger (H x W x D):	Portrait: 1728 x 832 x 42 mm Landscape: 828 x 1732 x 42 mm
Outside dimension incl. hanger (H x W x D):	Portrait: 1970 (\pm 30 mm) x 832 x 42 mm Landscape: 1054 (\pm 30 mm) x 1732 x 42 mm
Writing surface:	Double sided white enamel 14 mm (Indoor Air Quality Certified to SCS-EC10.3-2014 v4.0)
Gross weight:	20 kg
Nett weight:	11,5 kg
Charastaristics:	Magnetic and dry erasable, portable/moveable
Guarantee:	2 years
Guarantee surface	25 year on writability and dry erasability

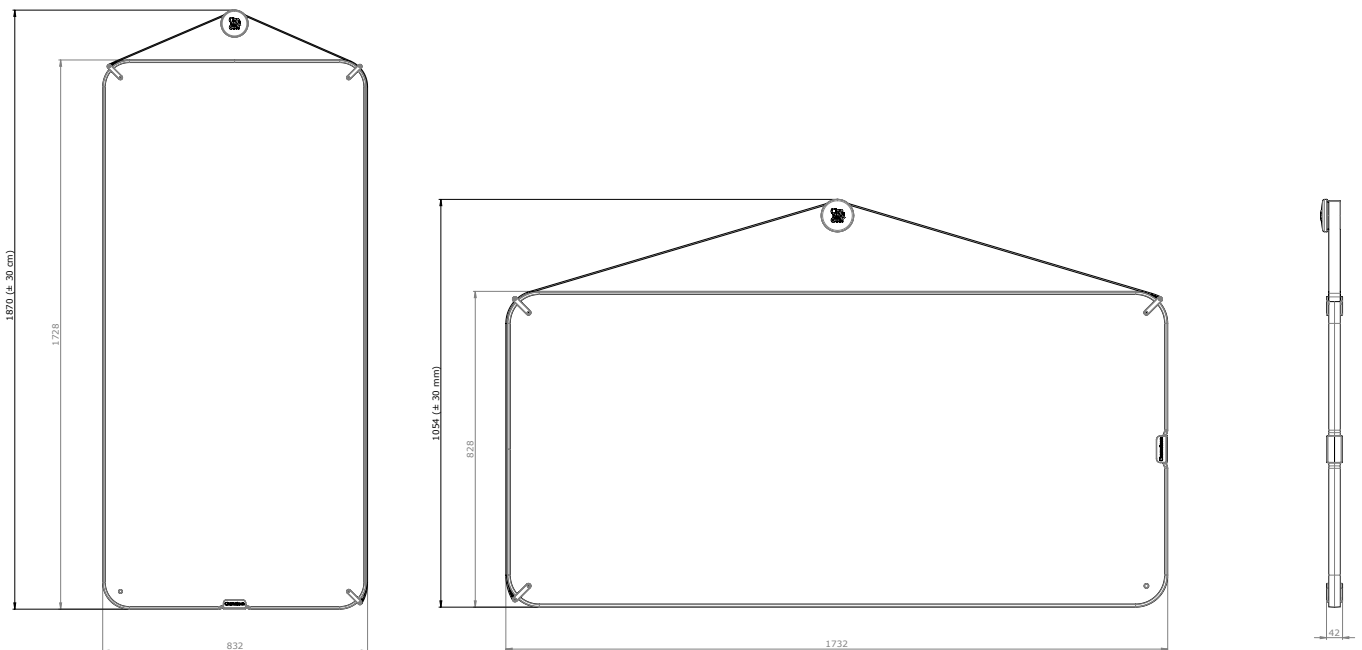

Packaging

Type:	Crate
Packing unit:	1 unit
Materials:	Pinewood + currogated cardboard + foamstrip + handwrap foil
Size (W x D x H):	(+/-) 1006 x 1862 x 80 mm
Weight packaging:	(+/-) 8,5 kg

Construction

Finishing:	Black rubber
Board per side:	White enamel steel sheet of 0.4 mm (Indoor Air Quality Certified to SCS-EC10.3-2014 v4.0)
Core:	Lightweight foam panel 25 mm
Carrying strap:	Real buffalo leather
Wall mount:	Synthetic

Recommended accessories

- 14017.111 - Starterkit whiteboards Universal
- 14021.103 - Magnetic pen holder
- 14016.155 - Whiteboard markers 4 pcs. assorted
- 14016.235 - Memo magnets 10 pcs. assorted, Ø 20 mm
- 14025.125 - Magnetic paper wiper Design
- 14020.200 - Microfiber cloth

