

Chameleon Writing Walls



- Specifications



Don't scale the size of your ideas to the size of your whiteboard

Chameleon Writing Wall is the first and only custom made, enameled whiteboard wall without a frame. We have the technology to cut frameless whiteboard panels into any size and any form. Allowing us to produce virtually seamless custom whiteboards in exactly the size of your wall.

Surface options

SURFACE MATERIAL	APPLICATION	ADVANTAGES
White enamel	Ideal for writing	Top-quality writing surface for whiteboards
Chalk gery/green (also enamelled steel)	Chalks	There is no better base material for the classic blackboard than this enamelled steel.
Sublimation steel (coated steel)	Sublimating (printing)	Ideal for combining the best full-colour prints with a writing application.

SURFACE MATERIAL	APPLICATION	ADVANTAGES	GAIN VALUE Hotspotting (distracting reflection) is determined by surface-material, light intensity and distance to beamer.
Mica white (also an enamelled steel)	Ideal for projection	Ideal properties for projection without reflection. Wet erase with a spray.	Luster level: about 20% (GS45°), 5° gain: about 1,8
Hybrid (also an enamelled steel)	Suitable for writing and semi-projection	A good compromis for anyone wanting to write and project on the same surface.	Luster level: about 50% (GS45°)

Guarantee

- Enamelled surfaces: 25 year guarantee on perfect erasability
- Coated staal (sublimation steel): 1 year guarantee on perfect erasability
- Board itself: 2 year guarantee

Technical properties Smit Visual enamelled steel

- Baked on 800°C, creating a perfectly smooth surface
- Consists of a double layer of enamel, which prevents any rust formation
- Magnetic, suitable for all kinds of magnets
- Suitable for whiteboard markers, perfect erasability
- Scratchproof

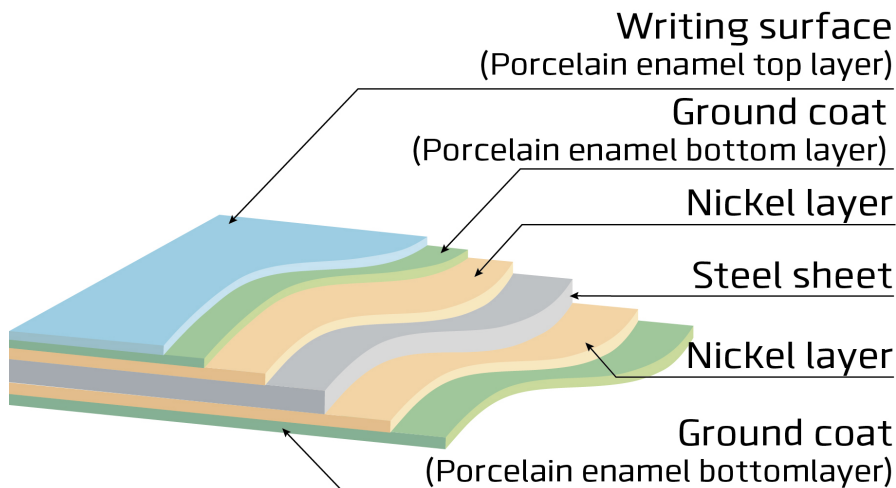

Construction

Chameleon panel

- 1. **Surface:** White enamel steel of 0.4 mm (Indoor Air Quality Certified to SCS-EC10.3-2014 v4.0)
- 2. **Carrier:** MDF 9 mm (FSC Mix Credit)
- 3. **Backing:** 0,4 mm galvanised steel sheet
- 4. **Finishing:** White lacquered edges

Magnetic mounting plate

- 4. **Magnetic sheet:** Anisotropic magnet, 1,5 mm thick
- 5. **Adhesive layer:** Double-sided tape
- 6. **Mounting plate:** Galvanised steel plate, 3 mm thick, with holes for screwing

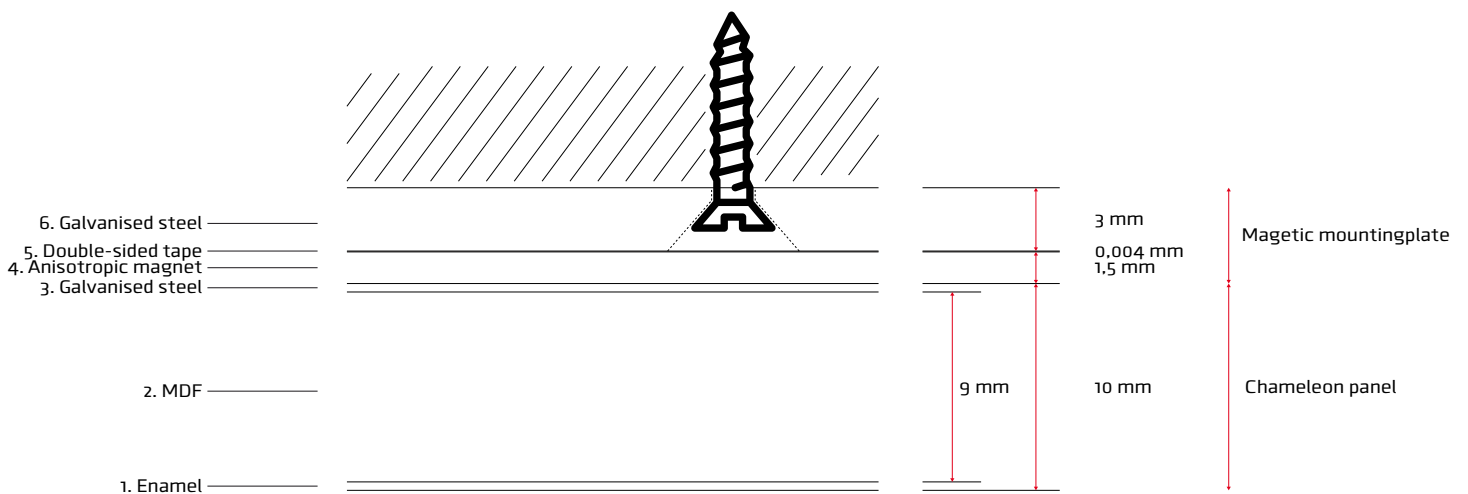
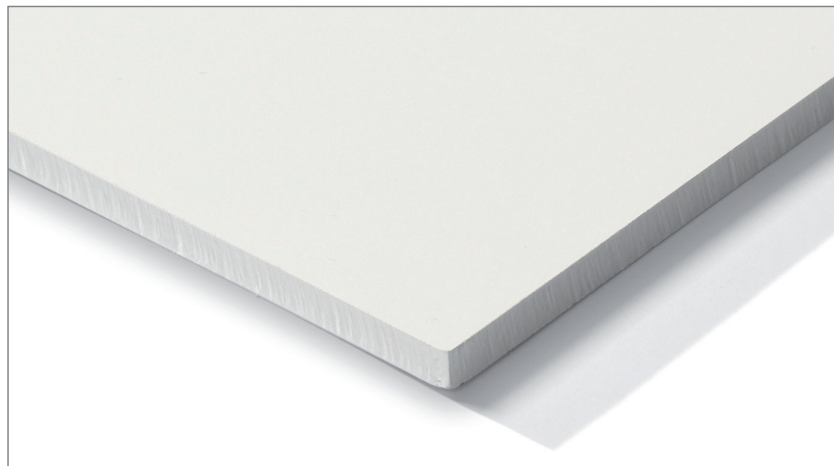

(Custom made) whiteboard wall

We recommend that measurement is not carried out by the client. We can provide you with training in carrying out measurements and partitioning the board correctly.

Tolerances

Although manufacturer Smit Visual always strives for optimal dimensional stability, account must be taken of minimum deviation in dimensions and perpendicularity.

Mounting (magnetic)

- With each Chameleon whiteboard wall, the manufacturer supplies a project-specific assembly drawing (see example in Annex 1).
- Panels can be easily aligned.
- Magnetic mounting allows for very easy mounting, the customer can do it all by himself.
- We recommend using suction cups (article number: 51508.010).
- The wall must be flat and free of obstacles.

Warning: Provided screws and plugs are suited for solid stone walls. In case of other walls make sure you choose suited mounting materials! Keep in mind that the screw head should fit deep enough into the steel plate, because of the magnet!

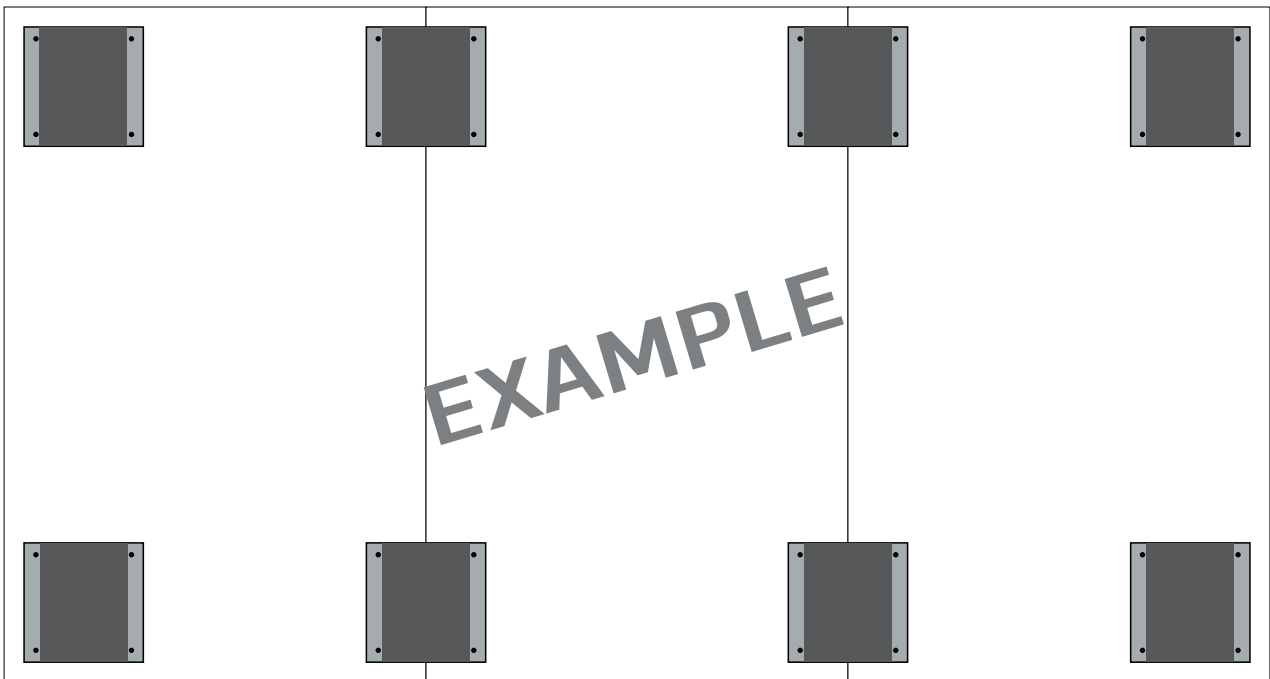

Mounting video



CO₂ neutral

Chameleon whiteboard walls are produced completely CO₂ neutral in our local factory in Geldrop, The Netherlands. Manufacturer Smit Visual takes actions to reduce emissions. The remaining emissions are compensated by planting forest through the globally recognized organization Trees For All.

FSC® certified

Manufacturer Smit Visual is FSC® certified. As a certified producer they can demonstrate that the materials used are derived from responsible forest management. In addition, the wood is traceable throughout the chain, from the forest to the end product. For more information about specific FSC labeling at product level, ask for an explanation.

Made in The Netherlands

The production of Chameleon whiteboards takes place entirely in Geldrop in the Netherlands. This guarantees fast delivery, great flexibility in customization and, moreover, a view on a socially responsible production process.





ATTENTION!

Provided screws and plugs are suited for solid stone walls. In case of other walls make sure you choose suited mounting materials! Keep in mind that the screw head should fit deep enough into the steel plate, because of the magnet!

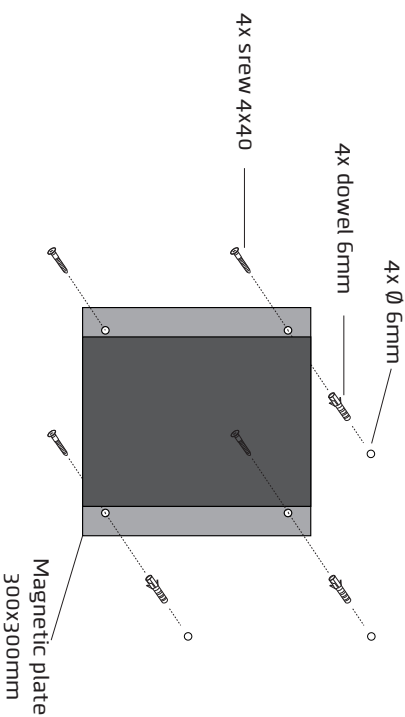

Annex 1

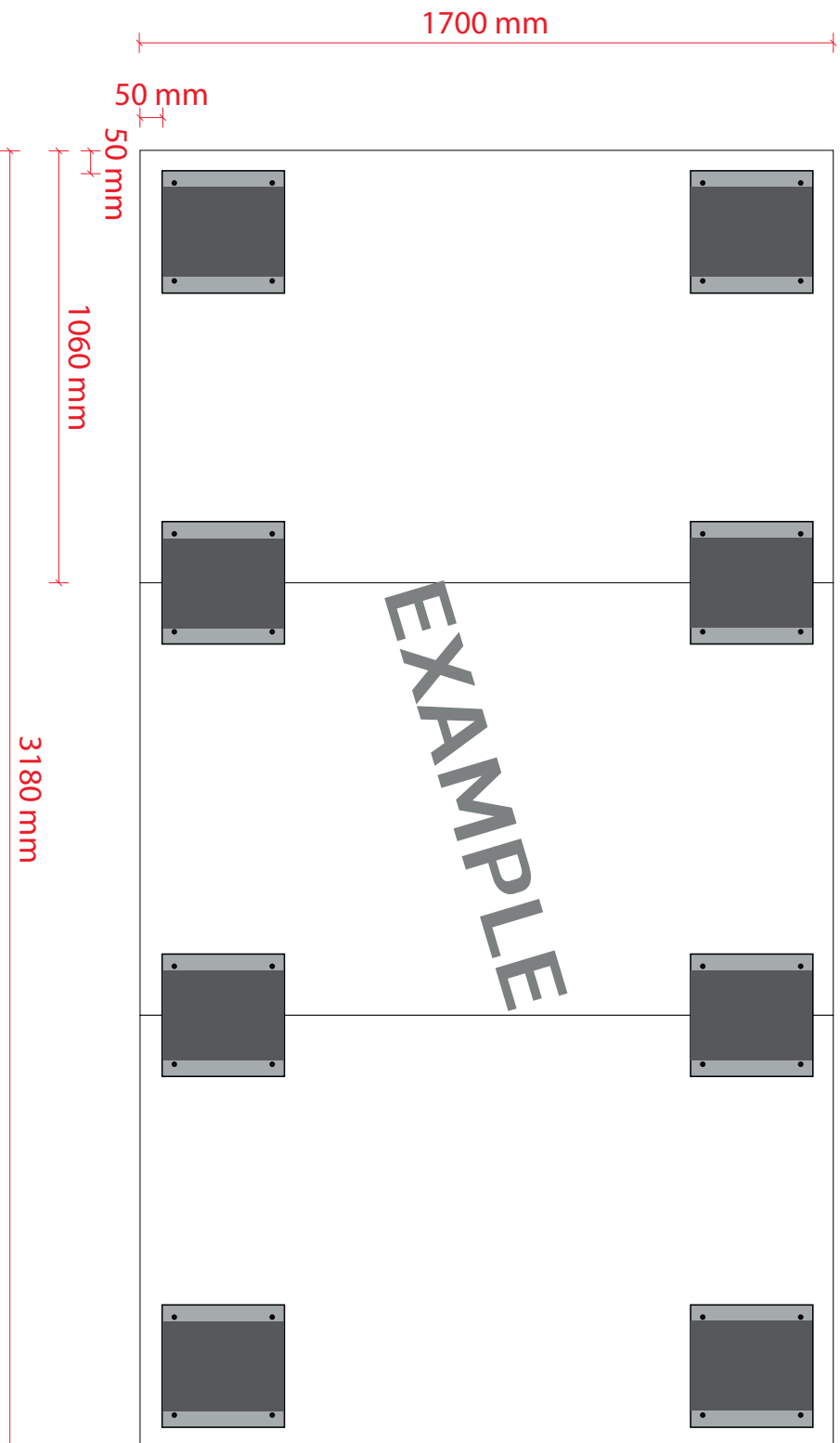

Customer:	Order number:
Description:	Size (WxH): 3180x1700 mm
Amount: 1	Amount of magnetic plates: 8
Amount of panels per wall: 3	Amount of screws and dowels: 32